

LABORATORY OIL-LESS DIAPHRAGM VACUUM PUMP & COMPRESSOR

OPERATION & MAINTENANCE MANUAL



Model DOA-P704 Shown

Thank you for purchasing this Gast product. It is manufactured to the highest standards using quality materials. Please follow all recommended maintenance, operational and safety instructions and you will receive years of trouble free service.

IMPORTANT: PLEASE READ THIS MANUAL AND SAVE FOR FUTURE REFERENCE.

Product Use Criteria:

- Pump only clean, dry air.
- Operate at 32°F - 104°F (0°C - 40°C).
- Protect unit from dirt & moisture.
- Do not pump flammable or explosive gases or use in an atmosphere that contains such gases.
- Protect all surrounding items from exhaust air. This exhaust air can become very hot.
- Corrosive gases and particulate material will damage unit. Water vapor, oil-based contaminants or other liquids must be filtered out.
- Consult your Gast Distributor/Representative before using at high altitudes.
- This pump is oil-less and requires NO lubrication.
- Laboratory units may be used for both pressure and vacuum.



ISO 9001 & 14001 CERTIFIED

www.gastmfg.com

Your safety and the safety of others is extremely important.

We have provided many important safety messages in this manual and on your product. Always read and obey all safety messages.



This is the safety alert symbol. This symbol alerts you to hazards that can kill or hurt you and others. The safety alert symbol and the words “DANGER” and “WARNING” will precede all safety messages. These words mean:

DANGER

You **will** be killed or seriously injured if you don't follow instructions.

WARNING

You **can** be killed or seriously injured if you don't follow instructions.

All safety messages will identify the hazard, tell you how to reduce the chance of injury, and tell you what can happen if the safety instructions are not followed.

INSTALLATION

WARNING



Electrical Shock Hazard

Disconnect electrical power at the circuit breaker or fuse box before installing this product.

Install this product where it will not come into contact with water or other liquids.

Install this product where it will be weather protected.

Electrically ground this product.

Failure to follow these instructions can result in death, fire or electrical shock.

Correct installation is your responsibility. Make sure you have the proper installation conditions and that installation clearances do not block air flow.

Blocking air flow over the product in any way can cause the product to overheat.

Mounting

This product can be installed in any orientation. Mounting the product to a stable, rigid operating surface and using shock mounts will reduce noise and vibration.

Plumbing

Remove plugs from the IN and OUT ports. Be sure to connect the intake and exhaust plumbing to the correct inlet and outlet ports. **Ports will not support the weight of the plumbing.**

Accessories

Filters and mufflers are supplied with some models. These should be checked periodically and replaced when necessary. An optional liquid trap should be installed between the line and the intake filter if this unit will be operated in a wet application. Please consult your Gast Distributor/Representative for additional filter recommendations.

Check valves may be required to prevent back streaming through the pump.

Motor Control

It is your responsibility to contact a qualified electrician and assure that the electrical installation is adequate and in conformance with all national and local codes and ordinances.

Select fuses, motor protective switches or thermal protective switches to provide protection. Fuses act as short circuit protection for the motor, not as protection against overload. Incoming line fuses must be able to withstand the motor's starting current. Motor starters with thermal magnetic overload or circuit breakers protect motor from overload or reduced voltage conditions. If additional information is required, please consult your Gast Distributor/Representative.

The wiring diagram supplied with the product provides required electrical information. Check that power source is correct to properly operate the dual-voltage motors.

Electrical Connection

WARNING

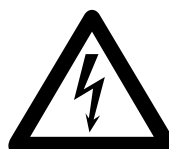

Electrical Shock Hazard

This product must be properly grounded.

Do not modify the plug provided. If it will not fit the outlet, have the proper outlet installed by a qualified electrician.

If repair or replacement of the cord or plug is necessary, do not connect the grounding wire to either flat blade terminal. The wire with insulation that is green with or without yellow stripes is the grounding wire.

Check the condition of the power supply wiring. Do not permanently connect this product to wiring that is not in good condition or is inadequate for the requirements of this product.

Failure to follow these instructions can result in death, fire or electrical shock.

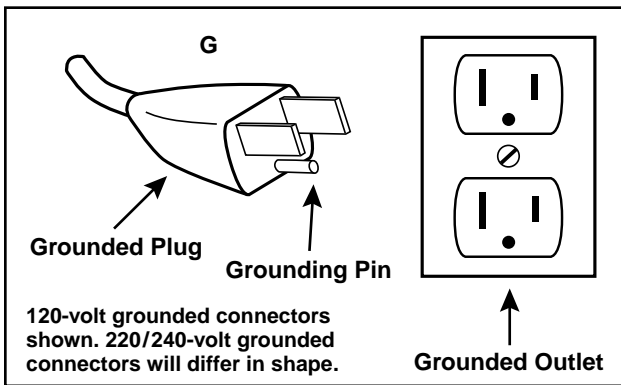

Model with a power supply cord:

This product must be grounded. For either 120-volt or 220/240-volt circuits connect power supply cord grounding plug to a matching grounded outlet. Do not use an adapter. (See DIAGRAM A)

In the event of an electrical short circuit, grounding reduces the risk of electric shock by providing an escape wire for the electric current. This product may be equipped with a power supply cord having a grounding wire with an appropriate grounding plug. The plug must be plugged into an outlet that is properly installed and grounded in accordance with all local codes and ordinances.

Check with a qualified electrician or serviceman if the grounding instructions are not completely understood, or if you are not sure whether the product is properly grounded. Do not modify the plug provided. If it will not fit the outlet, have the proper outlet installed by a qualified electrician.

Model that is permanently wired:

This product must be connected to a grounded, metallic, permanent wiring system, or an equipment grounding terminal or lead on the product.

Power supply wiring must conform to all required safety codes and be installed by a qualified person. Check that supply voltage agrees with that listed on product nameplate.

Extension cords:

Use only a 3-wire extension cord that has a 3-blade grounding plug. Connect extension cord plug to a matching 3-slot receptacle. Do not use an adapter. Make sure your extension cord is in good condition. Check that the gage wire of the extension cord is the correct size wire to carry the current this product will draw.

Minimum gage for extension cords										
Amps	Volts	Length of cord in feet								
	120v	25	50	100	150	200	250	300	400	500
	240v	50	100	200	300	400	500	600	800	1000
0-2		18	18	18	16	16	14	14	12	12
2-3		18	18	16	14	14	12	12	10	10
3-4		18	18	16	14	12	12	10	10	8
4-5		18	18	14	12	12	10	10	8	8
5-6		18	16	14	12	10	10	8	8	8
6-8		18	16	12	10	10	8	6	6	6
8-10		18	14	12	10	8	8	6	6	4
10-12		16	14	10	8	8	6	6	4	4
12-14		16	12	10	8	6	6	6	4	2
14-16		16	12	10	8	6	6	4	4	2
16-18		14	12	8	8	6	4	4	2	2
18-20		14	12	8	6	6	4	4	2	2

An undersized cord is a potential fire hazard, and will cause a drop in line voltage resulting in loss of power causing the product to overheat. The table indicates the correct size cord for length required and the ampere rating listed on the product nameplate. **If in doubt, use the next heavier gage cord. The smaller the gage number, the heavier the wire gage.**

OPERATION

! WARNING

Injury Hazard

Install proper safety guards as needed.

Keep fingers and objects away from openings and rotating parts.

When provided, motor terminal covers must be in place for safe operation.

Product surfaces become very hot during operation, allow product surfaces to cool before handling.

Air stream from product may contain solid or liquid material that can result in eye or skin damage, wear proper eye protection.

Wear hearing protection. Sound level from motor may exceed 70 dBA.

Failure to follow these instructions can result in burns, eye injury or other serious injury.

It is your responsibility to operate this product at recommended pressures or vacuum duties and room ambient temperatures. Do not start against a vacuum or pressure load.

Start Up

If motor fails to start or slows down significantly under load, shut off and disconnect from power supply. Check that the voltage is correct for motor and that motor is turning in the proper direction.

MAINTENANCE

! WARNING



Electrical Shock Hazard

Disconnect electrical power supply cord before performing maintenance on this product.

If product is hard wired into system, disconnect electrical power at the circuit breaker or fuse box before performing maintenance on this product.

Failure to follow these instructions can result in death, fire or electrical shock.

WARNING

Injury Hazard

Product surfaces become very hot during operation, allow product surfaces to cool before handling.

Air stream from product may contain solid or liquid material that can result in eye or skin damage, wear proper eye protection.

Clean this product in a well ventilated area.

Failure to follow these instructions can result in burns, eye injury or other serious injury.

It is your responsibility to:

- Regularly inspect and make necessary repairs to product in order to maintain proper operation.
- Make sure that pressure and vacuum are released from product before starting maintenance.

Check intake and exhaust filters after first 500 hours of operation. Clean filters and determine how frequently filters should be checked during future operation. This one procedure will help to assure the product's performance and service life.

Solvent Cleaning

Use only Gast AH255B Solvent or other non-petroleum based solvent. Do Not use kerosene or ANY other combustibile solvent to clean product.

1. Remove the four screws in the top of the product. Remove the top plate.
2. Remove filters and clean with Gast AH255B solvent or other non-petroleum based solvent. Use compressed air to dry filters and make sure that all moisture is removed. Reinstall filters.
3. Inspect head and O-ring for damage.
4. Reinstall head and valve plate with four screws.

Check that all external accessories such as relief valves and gauges are attached to cover and are not damaged before re-operating product.

SHUTDOWN PROCEDURES

It is your responsibility to follow proper shutdown procedures to prevent product damage. NEVER ADD OIL TO THIS OIL-LESS PUMP.

Proper shutdown procedures must be followed to prevent pump damage. Failure to do so may result in premature pump failure. This Gast Manufacturing Laboratory Oil-Less Diaphragm Vacuum Pump and Compressor is constructed of ferrous metals or aluminum which are subject to rust and corrosion when pumping condensable vapors such as water. Follow all the steps to assure correct storage and shutdown between operating periods.

1. Disconnect plumbing.
2. Operate product for at least 5 minutes without plumbing.
3. Run at maximum vacuum for 10 to 15 minutes.
4. Repeat step 2.
5. Disconnect power supply.
6. Plug open ports to prevent dirt or other contaminants from entering product.

SERVICE KIT INSTALLATION

WARNING



Electrical Shock Hazard

Disconnect electrical power supply cord before installing Service Kit.

If product is hard wired into system, disconnect electrical power at the circuit breaker or fuse box before installing Service Kit.

Disconnect air supply and vent all air lines to release pressure or vacuum.

Failure to follow these instructions can result in death, fire or electrical shock.

Gast will NOT guarantee field-rebuilt product performance. For performance guarantee, the product must be returned to a Gast Authorized Service Facility.

Service Kit contents vary. Most contain gaskets, valves and filter parts.

Disassembly

To make reassembly easier, note the location of parts when disassembling.

1. Disconnect electrical power to pump.
2. Disconnect air supply and vent all air lines to release pressure or vacuum.
3. Label pressure gauge, vacuum gauge and pump ports. Remove gauges if they interfere with head bolt removal.
4. Remove the four fasteners that hold the handle and head assembly in place. Lift washers and handle off studs on the back of unit. Remove head and valve plate from pump.

Replacing Diaphragm

1. Remove the two Phillips-head screws then the retainer plate and diaphragm.
2. Install the new diaphragm over the ring on the connecting rod. Place the pattern side up.
3. Apply Loctite® 222MS thread locker to the screws. Replace the retainer plate and attach with the two screws. Torque the screws to 30 in-lbs. Remove any excess Loctite®.

Replacing Leaf Valves

1. Separate head from valve plate. Remove then discard O-ring and filter elements.
2. Remove slotted valve screw. Remove valve limiter, leaf valves and valve retainer. Discard all valve components except the valve plate. **Do Not damage the valve plate.**
3. Clean pump head and valve plate using Gast AH255B solvent. Air dry. Do Not use petroleum-based solvents for cleaning. Do Not lubricate any parts.
4. Place valve plate so that the O-ring groove and raised valve seat are facing down.
5. Using thumb and middle finger, gently flex valve to find its natural inner curve. Place valve on valve seat with the natural inner curve facing down. Valve will only work correctly when the inner curve faces down on the valve seat.
6. Place valve retainer with sharp side up and notch away from valve.
7. Insert pan head screw through retainer, leaf valves and valve plate.
8. Support screw while turning over valve plate assembly. While holding screw in place, place leaf valve (inner curve over raised valve seat) over screw. Start valve limiter on threads of screw.

9. Align valve components and tighten screw to 12 to 13 in-lbs.

Reassembly

1. Place molded O-ring in valve plate O-ring groove. Make sure O-ring doesn't slip out of the groove.
2. Replace (2) filter elements in head with one element inside each open port chamber.
3. Set head on top of valve plate so O-ring is properly compressed and locating pin on head fits in locating hole on valve plate.
4. Remove the cooling fan grill. Rotate fan by hand until rod and diaphragm are at top dead center. Align and reinstall shims on top of pump body.
5. Install head and valve assembly on pump. Reinstall handle. Install the fasteners that hold the handle and head assembly in place and hand tighten. In a criss-cross torque pattern, run fasteners and nuts to 100 in-lbs.
6. Reinstall gauges and plumbing.

Check that all external accessories such as relief valves and gauges are attached to cover and are not damaged before re-operating product.

If pump still does not produce proper vacuum or pressure, send unit to a Gast Authorized Service Facility for repair.

WARRANTY

Gast finished products, when properly installed and operated under normal conditions of use, are warranted by Gast to be free from defects in material and workmanship for a period of twelve (12) months from the date of purchase from Gast or an authorized Gast Representative or Distributor. In order to obtain performance under this warranty, the buyer must promptly (in no event later than thirty (30) days after discovery of the defect) give written notice of the defect to Gast Manufacturing Incorporated, PO Box 97, Benton Harbor Michigan USA 49023-0097 or an authorized Service Center (unless specifically agreed upon in writing signed by both parties or specified in writing as part of a Gast OEM Quotation). Buyer is responsible for freight charges both to and from Gast in all cases.

This warranty does not apply to electric motors, electrical controls, and gasoline engines not supplied by Gast. Gast's warranties also do not extend to any goods or parts which have been subjected to misuse, lack of maintenance, neglect, damage by accident or transit damage.

THIS EXPRESS WARRANTY EXCLUDES ALL OTHER WARRANTIES OR REPRESENTATIONS EXPRESSED OR IMPLIED BY ANY LITERATURE, DATA, OR PERSON. GAST'S MAXIMUM LIABILITY UNDER THIS EXCLUSIVE REMEDY SHALL NEVER EXCEED THE COST OF THE SUBJECT PRODUCT AND GAST RESERVES THE RIGHT, AT ITS SOLE DISCRETION, TO REFUND THE PURCHASE PRICE IN LIEU OF REPAIR OR REPLACEMENT.

GAST WILL NOT BE RESPONSIBLE OR LIABLE FOR INDIRECT OR CONSEQUENTIAL DAMAGES OF ANY KIND, however arising, including but not limited to those for use of any products, loss of time, inconvenience, lost profit, labor charges, or other incidental or consequential damages with respect to persons, business, or property, whether as a result of breach of warranty, negligence or otherwise. Notwithstanding any other provision of this warranty, BUYER'S REMEDY AGAINST GAST FOR GOODS SUPPLIED OR FOR NON-DELIVERED GOODS OR FAILURE TO FURNISH GOODS, WHETHER OR NOT BASED ON NEGLIGENCE, STRICT LIABILITY OR BREACH OF EXPRESS OR IMPLIED WARRANTY IS LIMITED SOLELY, AT GAST'S OPTION, TO REPLACEMENT OF OR CURE OF SUCH NONCONFORMING OR NON-DELIVERED GOODS OR RETURN OF THE PURCHASE PRICE FOR SUCH GOODS AND IN NO EVENT SHALL EXCEED THE PRICE OR CHARGE FOR SUCH GOODS. GAST EXPRESSLY DISCLAIMS ANY WARRANTY OF MERCHANTABILITY OR FITNESS FOR A PARTICULAR USE OR PURPOSE WITH RESPECT TO THE GOODS SOLD. THERE ARE NO WARRANTIES WHICH EXTEND BEYOND THE DESCRIPTIONS SET FORTH IN THIS WARRANTY, notwithstanding any knowledge of Gast regarding the use or uses intended to be made of goods, proposed changes or additions to goods, or any assistance or suggestions that may have been made by Gast personnel.

Unauthorized extensions of warranties by the customer shall remain the customer's responsibility.

CUSTOMER IS RESPONSIBLE FOR DETERMINING THE SUITABILITY OF GAST PRODUCTS FOR CUSTOMER'S USE OR RESALE, OR FOR INCORPORATING THEM INTO OBJECTS OR APPLICATIONS WHICH CUSTOMER DESIGNS, ASSEMBLES, CONSTRUCTS OR MANUFACTURES.

This warranty can be modified only by authorized Gast personnel by signing a specific, written description of any modifications.

Please reference the exploded view on the next page for the following model and parts table.

DOA SERIES

REF	DESCRIPTION	QTY	DOA-P704-AA	DOA-P504-BN
1	PRESSURE GAUGE	1	AA806	AA806
2	PRESSURE REGULATOR – RELIEF VALVE	1	AF887	AH707
3	VACUUM GAUGE	1	AE136	AE136
4	VACUUM REGULATOR – RELIEF VALVE	1	AA550C-V	AA550C-V
5	HEAD	1	AP522A	AA522A
6 Δ	HEAD O-RING	1	AP513A	AP513A
7 Δ	FILTER/MUFFLER ELEMENT	2	AT712A	AT712A
8	HANDLE	1	AP523A	AP523A
9	VALVE PLATE	1	AP504	AP504
10 Δ	VALVE SCREW	1	BB330B	BB330B
11 Δ	VALVE LIMITER	1	AP110	AP110
12 Δ	LEAF VALVE	2	AF817	AF817
13 Δ	VALVE RETAINER	1	AF819A	AF819A
14	ELBOW	2	AG613	AG613D
15	RETAINER PLATE	1	AF809	AF809
16	DIAPHRAGM	1	AF818A	AF818A
17	FELT SPACER	3	AA929	AA929
18	SPACER	1	AD996	AD996
19	FAN	1	AT837	AT837
20	GRILLE	1	AF807	AF807
21	RUBBER FOOT	4	AF584A	AF584A
22	POWER CORD	1	AE941	AG320
23	REAR COVER	1	AF805B	AG954
24	VALVE PLATE ASSEMBLY	1	AP519	AP519
25	RETAINER PLATE SCREWS	2	BB557	BB557
	SERVICE KIT	1	K294J	K294K

Δ Denotes parts included in the Service Kit.

Δ The service kit may contain parts for more than one model or style diaphragm pump.
Parts not needed may be discarded.

Parts listed are for stock models. For specific OEM models, please consult the factory.
When corresponding or ordering parts, please give complete model and serial numbers.

EXPLODED PRODUCT VIEWS - MODEL DOA & VALVE PLATE ASSEMBLY

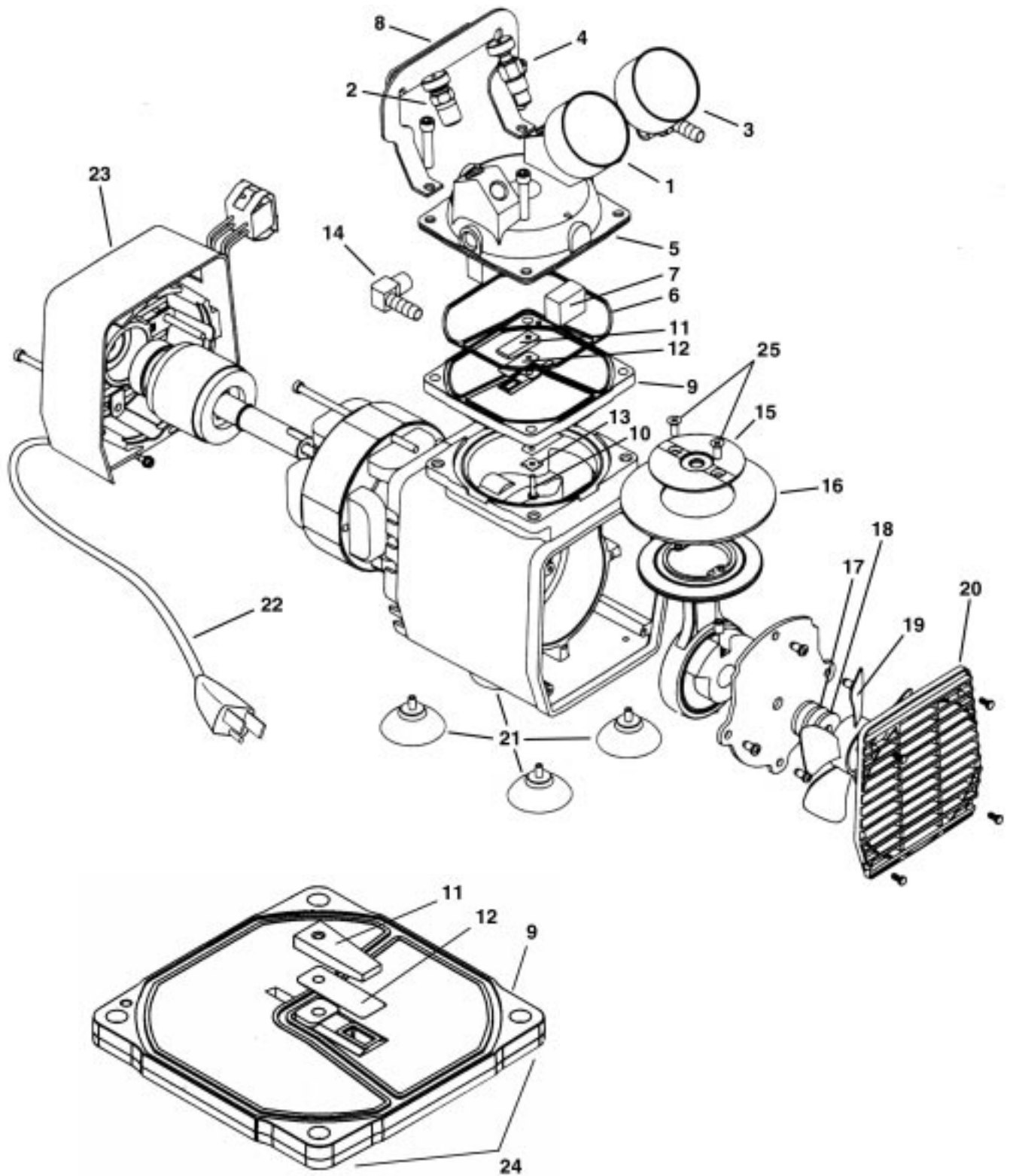

Valve Plate Assembly (available separately)

Valve Plate Assembly also includes
items 10 & 13 (not shown)

PART NO. 70 - 5105 G471PL (Rev A)

TROUBLESHOOTING CHART

Low		High		Pump Overheat	Motor Overload	Excess Noise	Reason and remedy for problem.
Vacuum	Pressure	Vacuum	Pressure				
•	•	At Pump		•	•		Filter dirty. Clean or replace.
•	•		At pump	•	•		Muffler dirty. Clean or replace.
•	•						Valves dirty or valves bent. Clean or replace.
•	•						Worn diaphragm. Repair or replace.
			•	•	•		Relief valve set too high. Inspect and adjust.
•	•						Relief valve set too low. Inspect and adjust.
•	•	At pump	At pump	•	•		Plugged vacuum/pressure line. Inspect and repair.
•		At pump					Collapsed vacuum line. Inspect and repair.
				•	•		Low voltage, won't start. Check power source.
				•	•	•	Voltage wrong. Check power source.
•	•					•	Worn diaphragm. Replace.
•	•						Leaky hose or check valve. Replace.
•	•			•	•	•	Dirt or liquid on top of diaphragm. Inspect and clean.
•	•			•	•		Motor not wired correctly. Check wiring diagram/line voltage.

AUTHORIZED SERVICE FACILITIES

Gast Manufacturing Inc.
2550 Meadowbrook Road
Benton Harbor, MI 49022
TEL: 269-926-6171
FAX: 269-925-8288
www.gastmfg.com

Gast Manufacturing Inc.
505 Washington Avenue
Carlstadt, NJ 07072
TEL: 201-933-8484
FAX: 201-933-5545
www.gastmfg.com

Air-Oil Products Corp.
301 30th Street NE 31, #112
Auburn, WA 98002
TEL: 800-282-2672
FAX: 877-808-4601
www.air-oil.com

Brenner Fiedler & Assoc
13824 Bentley Place
Cerritos, CA 90701
TEL: 800-843-5558
TEL: 310-404-2721
FAX: 310-404-7975
www.brenner-fiedler.com

D & F Distributors
1144 Indy Court
Evansville, IN 47725
TEL: 812/867-2441
FAX: 812/867-6822
www.dfdistrib.com

John Henry Foster Co.
4700 Lebourget Drive
St. Louis, MO 63134-0820
TEL: 314-427-0600
TEL: 1-800-444-0522
FAX: 314-427-3502
www.jhf.com

Hydraulic & Pneumatic Sales
11100 Park Charlotte Blvd.
Charlotte, NC 28273
TEL: 704-588-3234
FAX: 704-588-1569
www.hpsalesinc.com

Kinequip, Incorporated
365 Old Niagara Falls Blvd.
Buffalo, NY 14228-1636
TEL: 716-694-5000
TEL: 1-800-982-8894
www.kinequip.com

James E. Watson & Co.
29 Doran Ave.
Marietta, GA 30060
TEL: 770/422-1154
www.jwatsonco.com

Wainbee Limited
5789 Coopers Avenue
Mississauga, Ontario
Canada L4Z 3S6
TEL: 905-568-1700
FAX: 905-568-0083
http://www.wainbee.ca

Wainbee Limited
215 boul Brunswick
Pointe Claire, Quebec
Canada H9R 4R7
TEL: 514-697-8810
FAX: 514-697-3070
http://www.wainbee.ca

Gast Manufacturing Co., Ltd.
Beech House
Knives Beech Business Centre
Loudwater, High Wycombe
Bucks, England HP10 9SD
TEL: 011-44 1628 532600
FAX: 011-44 1628 532470
http://www.gastltd.com

Japan Machinery Co., Ltd
Central PO Box 1451
Tokyo, 100-91 Japan
TEL: 81-3-3573-5421
FAX: 81-3-3571-7865
or: 81-3-3571-7896
www.japanmachinery.com



ISO 9001 & 14001 CERTIFIED

www.gastmfg.com